



# HYDRA-TECH PUMPS

## "ULTRA-LITE" HYDRAULIC POWER UNIT

MODEL HT3G



*This Honda powered Ultra-Lite power pack is primarily designed to drive our 2" Mini-Sub submersible pump. It can also provide very portable, self-contained, hydraulic power to run other hydraulic tools and equipment.*

### FEATURES

- Very Light - Weighs only 30 lbs.
- Reliable Honda 4 Cycle Gas Engine
- Low Engine Oil Safety Shutdown
- Gear Type Hydraulic Pump
- See-Thru Oil Reservoir
- One-Hand Carry Chassis
- Liquid Filled Pressure Gauge
- Pressure Control Valve
- System Relief Valve
- No-Spill, Q. D. Couplers

A0908



**HYDRA-TECH  
PUMPS**

167 Stock Street, Nesquehoning, PA USA Phone: 570-645-3779 Fax: 570-645-4061  
Website: [www.hydra-tech.com](http://www.hydra-tech.com) E-Mail: [htpump@hydra-tech.com](mailto:htpump@hydra-tech.com)

## Model HT3G Overall Dimensions

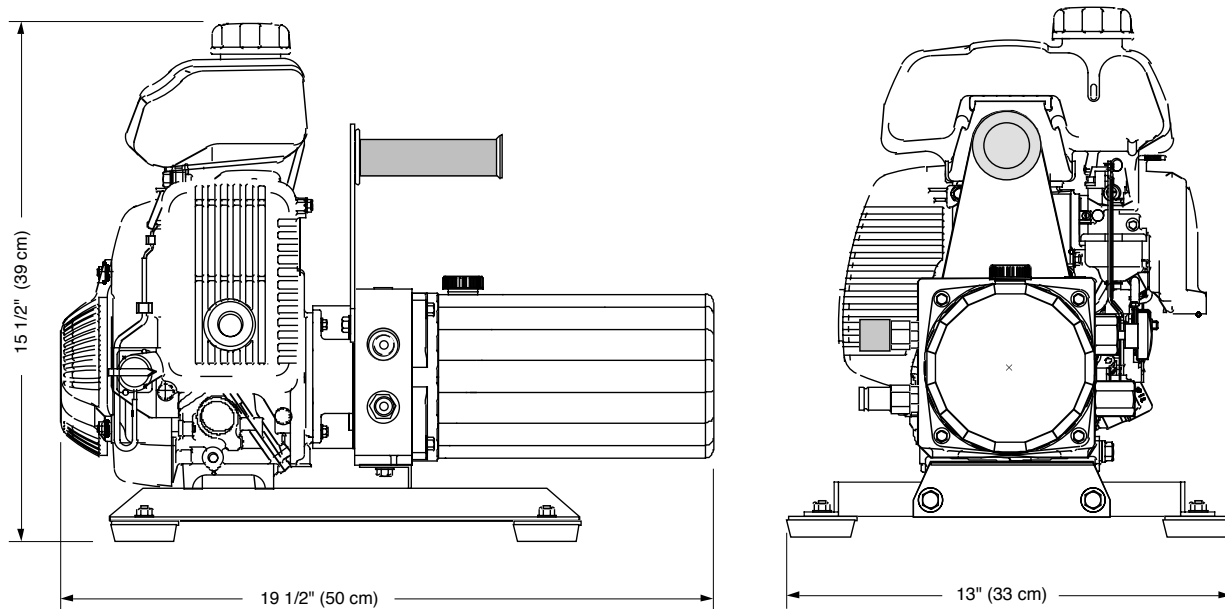

## SPECIFICATIONS

ENGINE:..... Honda GX100 Gasoline  
 HORSE POWER (KW):..... 3 (2.2) @ 4000 RPM  
 HYDRAULIC OUTPUT:..... 1.2 GPM (4.5 LPM) @ 2400 PSI (163 Bar)  
 HOSE PORT SIZE:..... 3/8" (#6)SAE  
 HYDRAULIC OIL:..... SAE 10W or 20W Type AW  
                     also...Dexron ATF or Bio-degradeable Oil (Consult Factory)  
 OIL RESERVOIR CAPACITY:..... 1.7 U.S. Quarts (1.6 Liters)  
 FUEL TANK CAPACITY:..... .81 U.S. Quarts (.77 Liters)  
 FUEL CONSUMPTION:..... Approx. .76 U.S. Quarts/Hr (.7 Liters/Hr)  
 RUNNING TIME:(1 tank of fuel@ full load)..... 1 1/4 Hours  
                     (1 tank of fuel@ half load@ 2000 RPM).....2 1/2 Hours  
 DIMENSIONS:..... H 15 1/2" (39 cm) x W 13" (33 cm) x L 19 1/2" (50 cm)  
 WEIGHT (Dry):..... 43 lbs. (19 kg)  
                     (With fuel and hydraulic oil):..... 48 lbs. (22 kg)

Since we are constantly working to improve our products, specifications are subject to change without notice.



167 Stock Street, Nesquehoning, PA USA Phone: 570-645-3779 Fax: 570-645-4061  
 Website: [www.hydra-tech.com](http://www.hydra-tech.com) E-Mail: [htpump@hydra-tech.com](mailto:htpump@hydra-tech.com)