

PORTABLE HYDRAULIC POWER UNIT

MODEL HT15GAT

This Honda powered gas unit features an electronic auto -throttle allowing you to set the unit to a desired hydraulic output and once under load the engine will speed up to this setting. This unit is perfect for operating hydraulic tools and pumps that will demand full power only as needed. This saves fuel and extends the life of the equipment.



FEATURES

- Advanced Honda IGX series engine
 - Auto -Throttling Variable Speed Control
 - Roll Cage Frame with Single Point Lift
 - Oil-Alert Engine Safety Shutdown
 - Gear-Type Hydraulic Pump
 - 10 Micron Spin-On Return Filter
 - Tank Top Filler/ Strainer
 - System Relief Valve
 - Hydraulic Oil Cooler
 - Pressure Control Valve
 - Liquid Filled Pressure Gauge
 - Fluid Level/ Temperature Gauge
- OPTIONS:**
- Wheel Kit
 - 20 Amp Alternator
 - 115 Volt A.C. Power Inverter
 - Other Flow and Pressure Combinations

A0508

Model HT15GAT Overall Dimensions

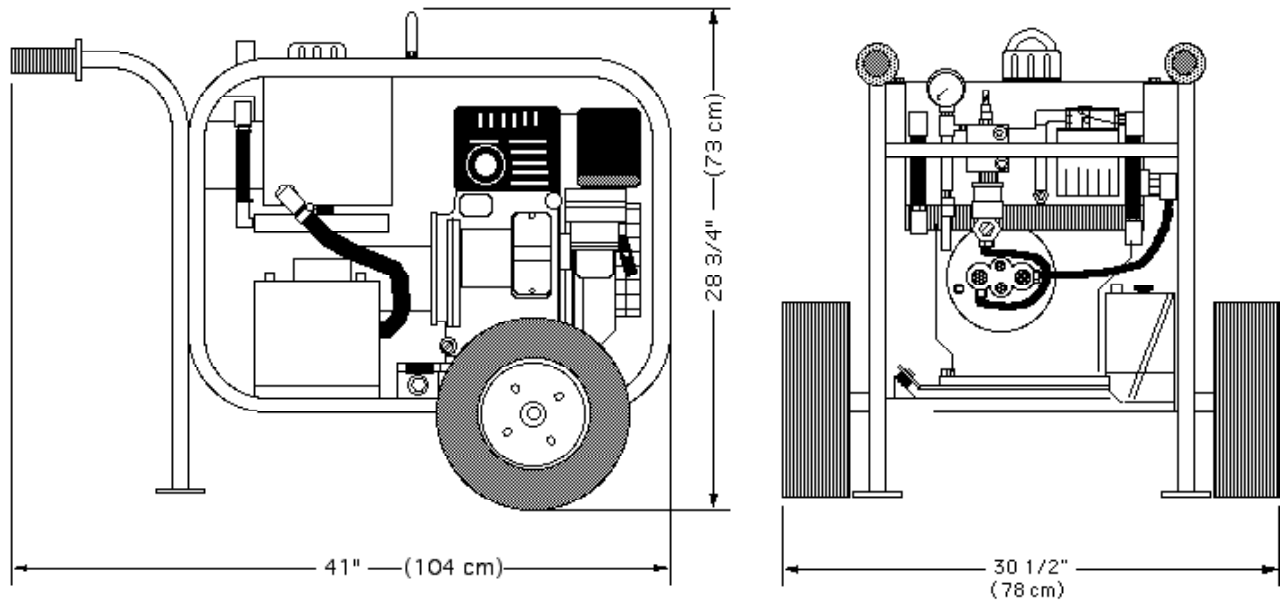

SPECIFICATIONS

ENGINE:.....Honda IGX440 Gasoline
 HORSE POWER:.....15 @ 3600 RPM
 HYDRAULIC OUTPUT:.....Variable Max 9 GPM (34 LPM)
 OPERATING PRESSURE:.....Maximum 2200 PSI (150 Bar)
 HOSE PORT SIZE:.....1/2" NPT
 HYDRAULIC OIL:.....SAE 10W or 20W Type AW
 also: Dextron ATF or Bio-degradeable oil (Consult Factory)
 OIL FILTRATION:.....10 Micron (Standard)
 OIL RESERVOIR CAPACITY:.....4 U.S. Gallons (15.1 Liters)
 FUEL TANK CAPACITY:.....1.6 U.S. Gallons (6 Liters)
 FUEL CONSUMPTION:.....Approx. 1 U.S. Gal/Hr (3.6Liters/Hr)
 DIMENSIONS:.....H 25" (63.5 cm) x W 20" (51 cm) x L 30" (76 cm)
 W/ Wheel Kit H: 28 3/4" (73 cm) x W 30 1/2" (78 cm) x L 41" (104 cm)
 WEIGHT (Dry):.....230 lbs. (104 kg)

* For Flows and Pressures Other Than Standard, Consult Factory

Since we are constantly working to improve our products, specifications are subject to change without notice.



**HYDRA-TECH
PUMPS**

167 Stock Street, Nesquehoning, PA USA Phone: 570-645-3779 Fax: 570-645-4061
 Website: www.hydra-tech.com E-Mail: htpump@hydra-tech.com