

PORTABLE HYDRAULIC POWER UNIT

MODEL HT13G



Unit Shown with Standard Roll Cage
Wheel Kit is Available

This Honda powered gas power pack is ideal for driving our 3" pumps and even our 6" propeller pump. It also can provide hydraulic power to run many other hydraulic tools now available.

FEATURES

- Reliable Honda Gas Engine
- Roll Cage Frame
- Optional Wheel Kit
- Single Point Lifting Bracket
- Gear Type Hydraulic Pump
- Efficient Oil Cooler
- System Relief Valve
- Pressure Control Valve
- Fluid Level Gauge
- Liquid Filled Pressure Gauge
- Spin-On 10 Micron Return Filter
- Low Engine Oil Safety Shutdown
- Optional Electric Start
- For Flows and Pressures Other Than Standard, Consult Factory

A0899

Model HT13G Overall Dimensions

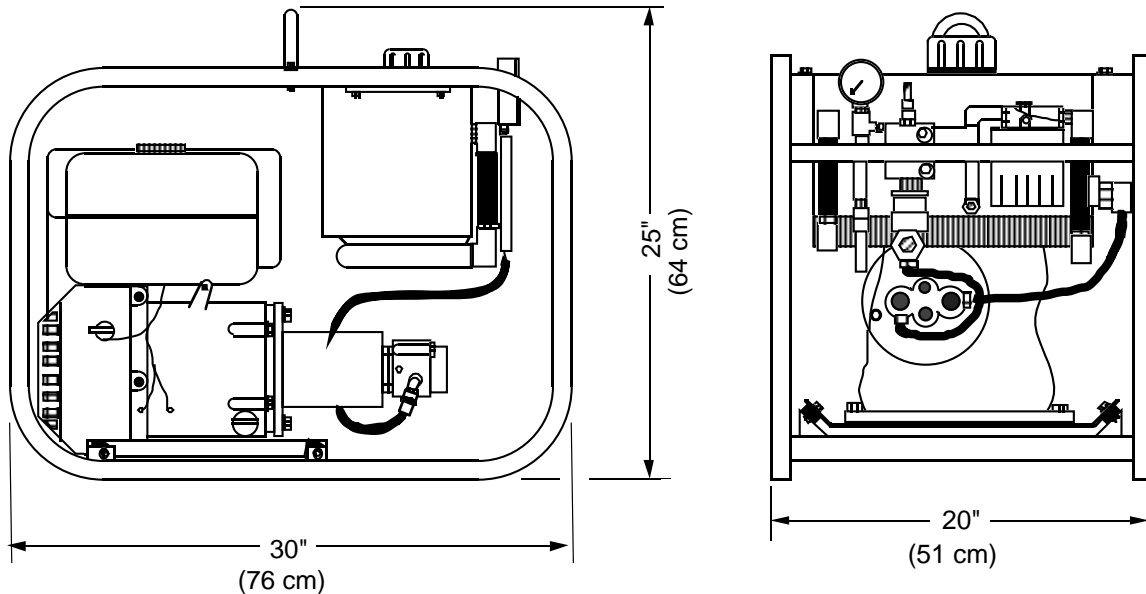

SPECIFICATIONS

ENGINE:.....Honda GX390 Gasoline
 HORSE POWER:.....13 @ 3500 RPM
 HYDRAULIC OUTPUT:.....Variable Max 6 GPM (23 LPM)
 OPERATING PRESSURE:.....Maximum 2100 PSI (143 Bar)
 HOSE PORT SIZE:.....1/2" NPT
 HYDRAULIC OIL:.....SAE 10W or 20W Type AW
 also: Dextron ATF or Bio-degradeable oil (Consult Factory)
 OIL FILTRATION:.....10 Micron (Standard)
 OIL RESERVOIR CAPACITY:.....4 U.S. Gallons (15.1 Liters)
 FUEL TANK CAPACITY:.....1.8 U.S. Gallons (6.8 Liters)
 FUEL CONSUMPTION:.....Approx. .9 U.S. Gal/Hr (3.4 Liters/Hr)
 DIMENSIONS:.....H 25" (63.5 cm) x W 20" (51 cm) x L 30" (76 cm)
 W/ Wheel Kit H: 28 3/4" (73 cm) x W 30 1/2" (78 cm) x L 41" (104 cm)
 WEIGHT (Dry):.....185 lbs. (84 kg)

Since we are constantly working to improve our products, specifications are subject to change without notice.