

PORTABLE HYDRAULIC POWER UNIT

MODEL HT11D

This portable diesel power pack is ideal for driving our 3" pumps and even our 6" propeller pump. It also can provide hydraulic power to run many other hydraulic tools now available.



Unit Shown with Optional Wheel Kit

FEATURES

- Efficient Yanmar Diesel Engine
- 12 Volt Electric Start
- Roll Cage Frame
- Single Point Lifting Bracket
- Gear Type Hydraulic Pump
- Efficient Oil Cooler
- System Relief Valve
- Pressure Control Valve
- Fluid Level Gauge
- Liquid Filled Pressure Gauge
- Spin-On 10 Micron Return Filter
- HTMA Hydraulic Couplers
- Optional Wheel Kit
- For Flows and Pressures Other Than Standard, Consult Factory

A0899

Model HT11D Overall Dimensions

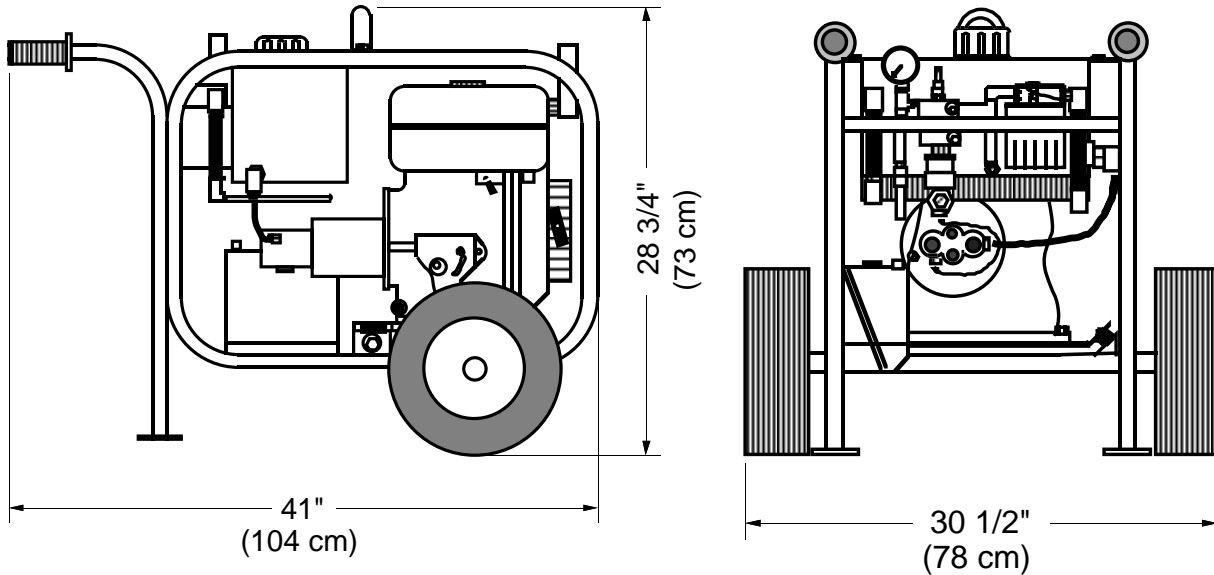

Dimensions shown with optional wheel kit

SPECIFICATIONS

ENGINE:.....Yanmar L100A Diesel
 HORSE POWER:.....11 @ 3500 RPM
 HYDRAULIC OUTPUT:.....Variable Max 6 GPM (23 LPM)
 OPERATING PRESSURE:.....Maximum 2100 PSI (143 Bar)
 HOSE PORT SIZE:.....1/2" NPT
 HYDRAULIC OIL:.....SAE 10W or 20W Type AW
 also...Dexron ATF or Bio-degradeable Oil (Consult Factory)
 OIL FILTRATION:.....10 Micron (Standard)
 OIL RESERVOIR CAPACITY:.....4 U.S. Gallons (15.1 Liters)
 FUEL TANK CAPACITY:.....1.45 U.S. Gallons (5.5 Liters)
 FUEL CONSUMPTION:.....Approx. .5 U.S. Gal/Hr (1.9 Liters/Hr)
 DIMENSIONS:.....H 25" (63.5 cm) x W 20" (51 cm) x L 30" (76 cm)
 W/ Wheel Kit H 28 3/4" (73 cm) x W 30 1/2" (78 cm) x L 41" (104 cm)
 WEIGHT (Dry):.....225lbs. (102 kg)

Since we are constantly striving to improve our products, specifications are subject to change without notice.