



2" and 3" Engine Driven Trash Pumps

- *Cast Aluminum Construction*
- *Pump Includes Heavy Duty Steel Roll Cage*
- *2" or 3" NPT Port Sizes*
- *Self-Priming to 25 Ft.*
- *Engine Options: B&S or Honda Gasoline; Yanmar Diesel*
- *Available with 4.7 to 8 HP Engines*
- *Solids Handling to 1-1/2" Diameter*
- *Viton® /Silicon Carbide Mechanical Seals*

The Gorman-Rupp line of Engine Driven trash pumps is designed for applications which require high flow efficiency and solids handling capability. Pumps are constructed of heavy duty sand cast aluminum components featuring replaceable ductile iron impellers and steel wearplates. Simple front cleanout design permits easy removal of trash and debris without disconnecting hoses. Pumps are available with Briggs & Stratton or Honda gasoline engine or Yanmar diesel engine. All are furnished with heavy-duty steel roll cages, suction strainers, and 90 degree discharge elbows.

*Viton® is a registered trademark of DuPont

PREMIUM HEAVY DUTY



Model 13D1-GX240

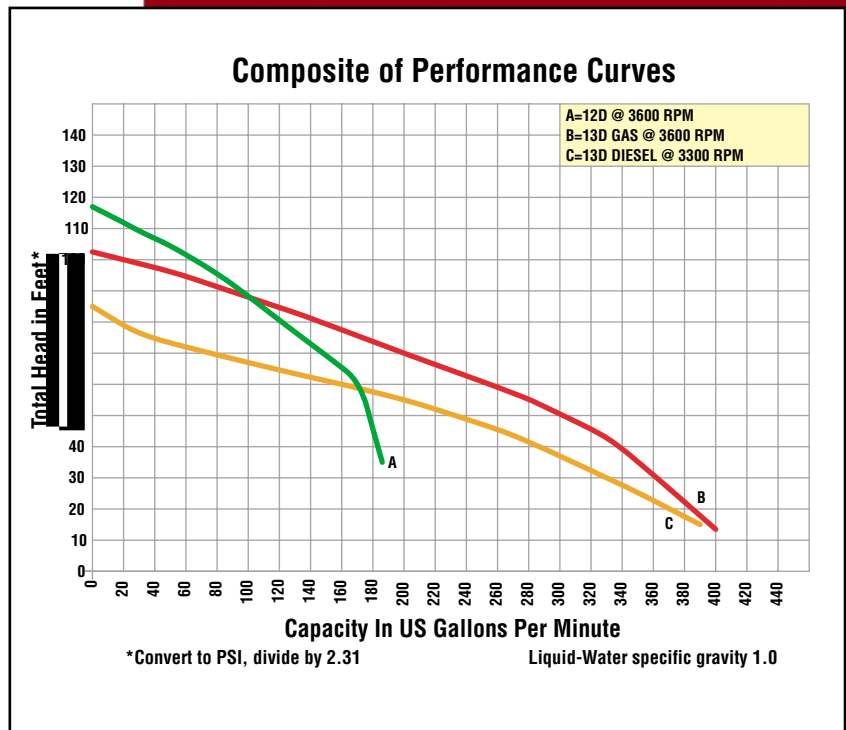

2" - 3" Engine Driven Trash Pumps

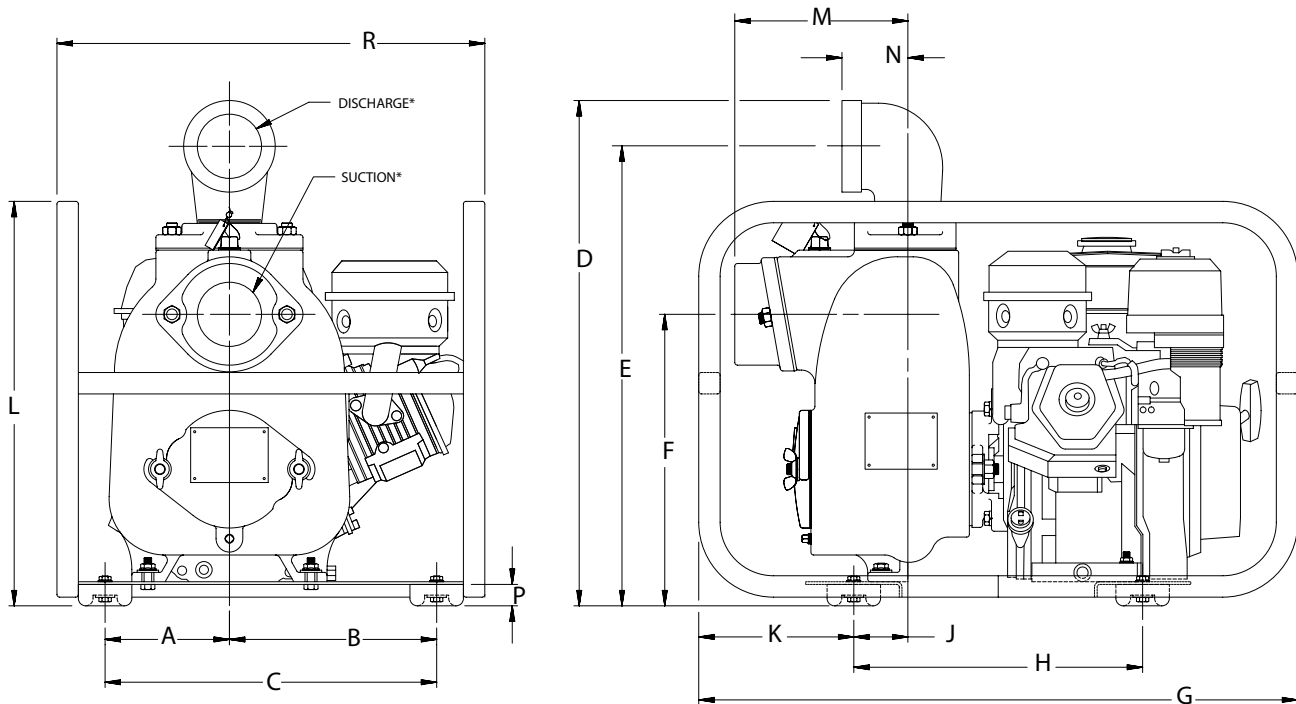

DIMENSIONS:
INCHES
[MILLIMETERS]

MODEL	A	B	C	D	E	F	G	H	J	K	L	M	N	P	R	SUCT*	DISCH*
12D1-11	6.12 [155,4]	10.88 [276,4]	17.00 [431,8]	20.94 [531,9]	19.47 [494,5]	10.84 [275,3]	22.00 [558,8]	12.00 [304,8]	2.56 [65,0]	5.00 [127,0]	18.12 [460,2]	6.00 [152,4]	2.25 [57,2]	.62 [15,7]	18.00 [457,2]	2.00	2.00
12D1-GX160	6.12 [155,4]	10.88 [276,4]	17.00 [431,8]	20.94 [531,9]	19.47 [494,5]	10.84 [275,3]	22.00 [558,8]	12.00 [304,8]	2.56 [65,0]	5.00 [127,0]	18.12 [460,2]	6.00 [152,4]	2.25 [57,2]	.62 [15,7]	18.00 [457,2]	2.00	2.00
12D1-L48EE	8.50 [215,9]	8.50 [215,9]	17.00 [431,8]	21.56 [547,6]	20.12 [511,0]	11.44 [290,6]	22.00 [558,8]	12.00 [304,8]	.96 [24,4]	5.00 [127,0]	18.12 [460,2]	5.96 [151,4]	2.25 [57,2]	.62 [15,7]	18.00 [457,2]	2.00	2.00
13D1-GX240	5.81 [147,6]	9.69 [246,1]	15.50 [393,7]	23.62 [599,9]	21.50 [546,1]	13.62 [345,9]	28.00 [711,2]	13.50 [342,9]	3.06 [77,7]	7.25 [184,2]	18.90 [480,1]	8.06 [204,7]	3.08 [78,2]	1.00 [25,4]	20.00 [508,0]	3.00	3.00
13D1-L70EE	9.81 [249,2]	10.19 [258,8]	20.00 [508,0]	24.41 [620,0]	22.28 [565,9]	14.44 [366,8]	28.00 [711,2]	13.50 [342,9]	2.28 [57,9]	7.25 [184,2]	20.87 [530,1]	8.06 [204,7]	3.08 [78,2]	.62 [15,9]	21.00 [533,4]	3.00	3.00
13D1-L70EE S/G	9.81 [249,2]	10.19 [258,8]	20.00 [508,0]	24.41 [620,0]	22.28 [565,9]	14.44 [366,8]	28.00 [711,2]	13.50 [342,9]	2.28 [57,9]	7.25 [184,2]	20.87 [530,1]	8.06 [204,7]	3.08 [78,2]	.62 [15,9]	21.00 [533,4]	3.00	3.00

(*) STANDARD NPT PIPE THREADS.

2" & 3" ENGINE DRIVEN TRASH PUMPS

Model No.	Description/ Type of Pump	Ship Wt (lbs.)	Driver Type & HP	Port size Suc x dis (NPT)	Basic Construction	Seal Type & Elastomer/Faces	Tank Size (Qts.)	Run time	Mounting
12D1-11	2" Engine Driven Trash Pumps	91	B&S 5.5 OHV	2" x 2"	Alum	Viton® Silicon-Carbide	3 qts.	2.1 hrs.	Roll Cage
12D1-GX160	2" Engine Driven Trash Pumps	84	Honda 5.5	2" x 2"	Alum	Viton® Silicon-Carbide	0.95 gal.	2.03 hrs.	Roll Cage
12D1-L48EE	2" Engine Driven Trash Pumps	138	Yanmar 4.7	2" x 2"	Alum	Viton® Silicon-Carbide	0.66 gal.	1.8 hrs.	Roll Cage
13D1-GX240	3" Engine Driven Trash Pumps	136	Honda 8	3" x 3"	Alum	Viton® Silicon-Carbide	1.6 gal.	2.7 hrs.	Roll Cage
13D1-L70EE	3" Engine Driven Trash Pumps	124	Yanmar 6.7	3" x 3"	Alum	Viton® Silicon-Carbide	0.92 gal.	2.2 hrs.	Roll Cage
13D1-L70EE S/G	3" Engine Driven Trash Pumps	124	Yanmar 6.7	3" x 3"	Alum	Viton® Silicon-Carbide	0.92 gal.	2.2 hrs.	Roll Cage

*Viton® is a registered trademark of DuPont

Standard Features

- Suction Strainer and 90° Discharge Elbow
- Self-primers to 25 ft. with Built-in Flapper Valve
- Replaceable Ductile Iron Impeller and Steel Wearplate
- Maximum Temperature 160° F
- Maximum Operating Pressure to 78 PSI
- Mechanical Seals
- Engine Options: Briggs & Stratton or Honda Gasoline; Yanmar Diesel
- Electric start (13D1-L70EE S/G)

WARNING: Do not use in explosive atmosphere or for pumping volatile flammable liquids.

See price book page 6

The Gorman-Rupp Company reserves the right to discontinue any model or change specifications at any time without incurring any obligation.

CP19-20 / 0906

